

EM-18

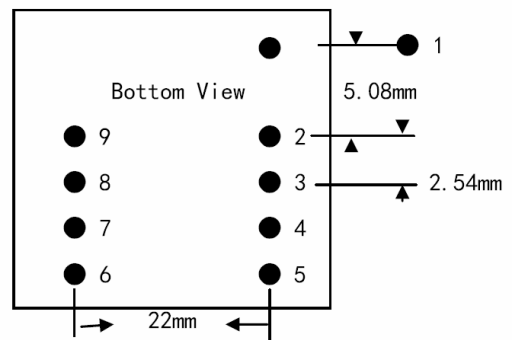

Tech parameter:

- Voltage: 2.7 to 5 volts
- Current usage: < 25mA
- Operating Frequency: 125 KHz
- Read Distance: 8 to 12 cm
- Output: Wiegand26 and Serial (TTL)
- With Internal Antenna



Basal Specifications:

No.	Pin Name	Descriptions
1	VCC	2.7 to 5 volts
2	GND	GND
3	BEEP OUT	Beep and LED Output (1.9KHz Sound)
4	ANT	Not Use
5	ANT	Not Use
6	SEL	High is Serial Low is Wiegand26
7	TXD	Serial Output '9600,N,8,1'
8	D1	Wiegand26 DATA1
9	D0	Wiegand26 DATA0

Pin Description Table

Output format:

1. Wiegand26 (format):

Weigand protocol provides 2 lines for data transfer. A pulsed transition on the DATA1 line indicates a logic 1 bit, while a pulsed transition on the DATA0 line indicates a logic 0 bit. In their idle state both lines are held high. During data transfer the appropriate logic line will pulse low for 63µs followed by a period of 2ms where both lines are held high. In this fashion each bit is transmitted in sequence until all bits are sent.

The end of the transmission is signaled by both lines being held high for more than 50ms. Figure1 shows an example of the timing sequence for Weigand protocol.

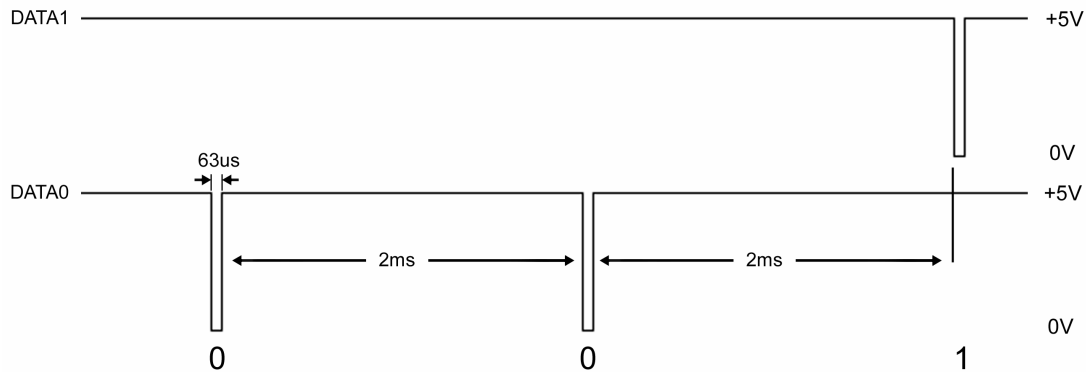
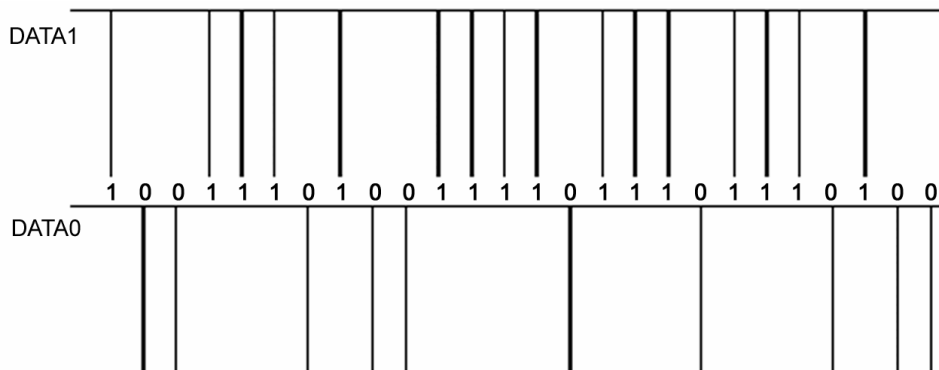

Figure 1: Weigand protocol waveform.

Wiegand 26 input format description:



Example WIEGAND26 Output Data for the Tag Number is: 0003832762

Weigand26 protocol is defined as a stream of 26 bits, consisting of 1 Even parity bit, 24 data bits, and 1 Odd parity bit.

Bit	0	1	2	3	4	5	6	7	8	9	10	11	12	13	14	15	16	17	18	19	20	21	22	23	24	25
Note		D	D	D	D	D	D	D	D	D	D	D	D	D	D	D	D	D	D	D	D	D	D	D	D	
	P	E	E	E	E	E	E	E	E	E	E	E	E													
														O	O	O	O	O	O	O	O	O	O	O	O	P
Sample	1	0	0	1	1	1	0	1	0	0	1	1	1	1	0	1	1	1	0	1	1	1	0	1	0	0

Note: P: parity Start and Stop Bits, E: Summed for Even parity (XOR 12bit from High Data) O: Summed for odd parity (XOR 12bit from Low Data) D: Data code for card: the data will use the last 24 data bits of card.

For Example:

Card HEX code is: 5D003A7BBA Card unique code is: 0003832762; convert the last 24 data bits of card code to Decimal: 3A7BBA >>Dec>> 0003832762 (Code printed on the Tags).

2. RS-232 interface format:

Serial Port Description:

1. Data baud rate: 9600 bps 2. data bit: 8-bits 3. Parity check: none 4. stop bit : 1

- Output Data format is 10 ASCII DATA (card HEX no.) + 2 ASCII DATA (XOR result). For example: Card code is '5D003A7BBA', XOR code is 'A6'. Output code: '5D003A7BBA6' without enter code (CR+LF).

	HEX Number Card										XOR	
ASCII	5	D	0	0	3	A	7	B	B	A	A	6
HEX	35	44	30	30	33	41	37	42	42	41	41	36

Decimal Unique Code (printed on the Tags):

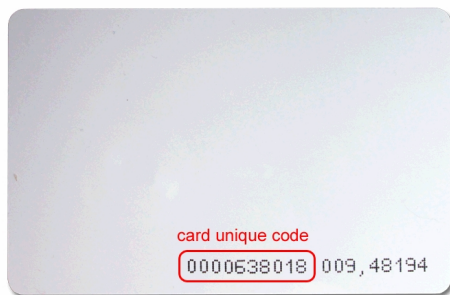

For the 10-digit Decimal Unique Code printed on the Card or Tags, Convert 3-Byte (The last 6 ASCII code) to Decimal (10-Digit Format).

For Example the Card HEX Code is '1E009BC42' Convert HEX (09BC42) To Decimal: **0000638018** (Code printed on the Card).

3. Application Circuit:

