

# 2SC4926

Silicon NPN Epitaxial

# HITACHI

ADE-208-1128A (Z)  
2nd. Edition  
Mar. 2001

## Application

VHF / UHF wide band amplifier

## Features

- High gain bandwidth product  
 $f_T = 11 \text{ GHz Typ}$
- High gain, low noise figure  
 $PG = 16.5 \text{ dB Typ}$ ,  $NF = 1.1 \text{ dB Typ}$  at  $f = 900 \text{ MHz}$

## Outline

MPAK-4

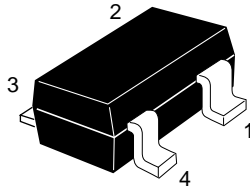

1. Collector
2. Emitter
3. Base
4. Emitter

Note: Marking is "YD-".

Attention: This is electrostatic sensitive device.

**Absolute Maximum Ratings** ( $T_a = 25^\circ\text{C}$ )

Item	Symbol	Rated	Unit
Collector to base voltage	$V_{\text{CBO}}$	15	V
Collector to emitter voltage	$V_{\text{CEO}}$	8	V
Emitter to base voltage	$V_{\text{EBO}}$	1.5	V
Collector current	$I_{\text{C}}$	50	mA
Collector power dissipation	$P_{\text{C}}$	150	mW
Junction temperature	$T_{\text{j}}$	150	$^\circ\text{C}$
Storage temperature	$T_{\text{stg}}$	-55 to +150	$^\circ\text{C}$

**Electrical Characteristics** ( $T_a = 25^\circ\text{C}$ )

Item	Symbol	Min	Typ	Max	Unit	Test conditions
Collector to base breakdown voltage	$V_{(\text{BR})\text{CBO}}$	15	—	—	V	$I_{\text{C}} = 10 \mu\text{A}$ , $I_{\text{E}} = 0$
Collector cutoff current	$I_{\text{CBO}}$	—	—	10	$\mu\text{A}$	$V_{\text{CB}} = 12 \text{ V}$ , $I_{\text{E}} = 0$
	$I_{\text{CEO}}$	—	—	1	mA	$V_{\text{CE}} = 8 \text{ V}$ , $R_{\text{BE}} = \infty$
Emitter cutoff current	$I_{\text{EBO}}$	—	—	10	$\mu\text{A}$	$V_{\text{EB}} = 1.5 \text{ V}$ , $I_{\text{C}} = 0$
DC current transfer ratio	$h_{\text{FE}}$	50	120	250		$V_{\text{CE}} = 5 \text{ V}$ , $I_{\text{C}} = 20 \text{ mA}$
Collector output capacitance	$C_{\text{ob}}$	—	0.6	1.1	pF	$V_{\text{CB}} = 5 \text{ V}$ , $I_{\text{E}} = 0$ , $f = 1 \text{ MHz}$
Gain bandwidth product	$f_{\text{T}}$	8.0	11.0	—	GHz	$V_{\text{CE}} = 5 \text{ V}$ , $I_{\text{C}} = 20 \text{ mA}$
$S_{21}$ Parameter	$ S_{21} $	—	16	—	dB	$V_{\text{CE}} = 5 \text{ V}$ , $I_{\text{C}} = 20 \text{ mA}$ , $f = 1000 \text{ MHz}$
Power gain	PG	13.5	16.5	—	dB	$V_{\text{CE}} = 5 \text{ V}$ , $I_{\text{C}} = 20 \text{ mA}$ , $f = 900 \text{ MHz}$
Noise figure	NF	—	1.1	2.0	dB	$V_{\text{CE}} = 5 \text{ V}$ , $I_{\text{C}} = 5 \text{ mA}$ , $f = 900 \text{ MHz}$

Maximum Collector Dissipation Curve

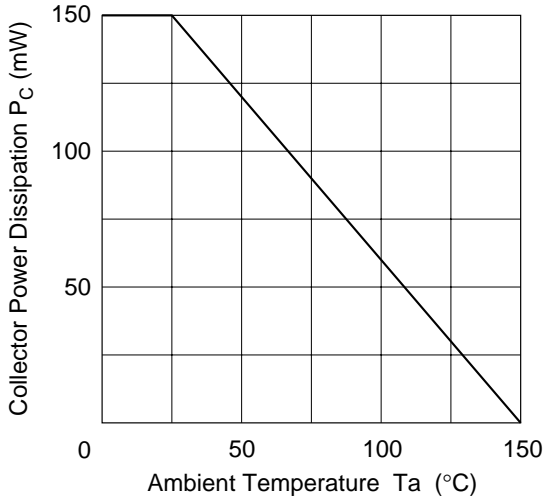

DC Current Transfer Ratio vs. Collector Current

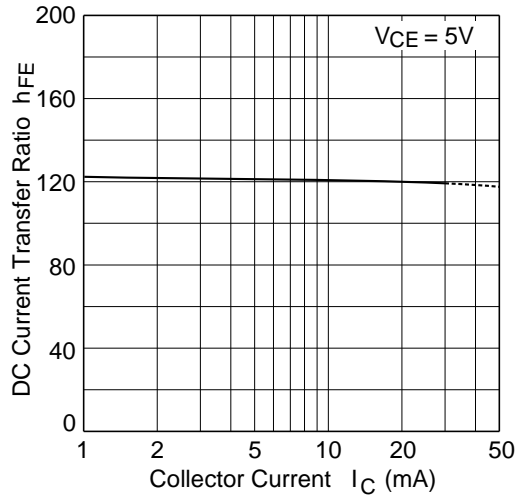

Gain Bandwidth Product vs. Collector Current

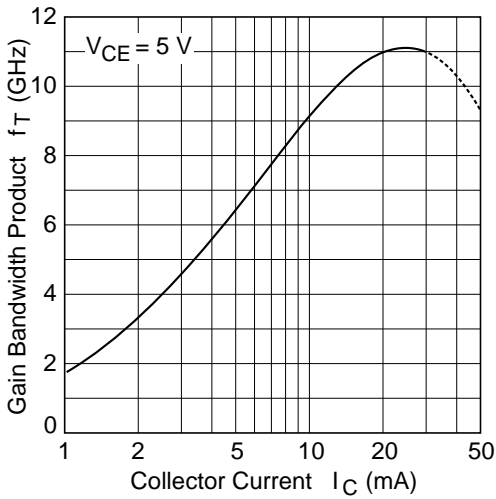

Collector Output Capacitance vs. Collector to Base Voltage

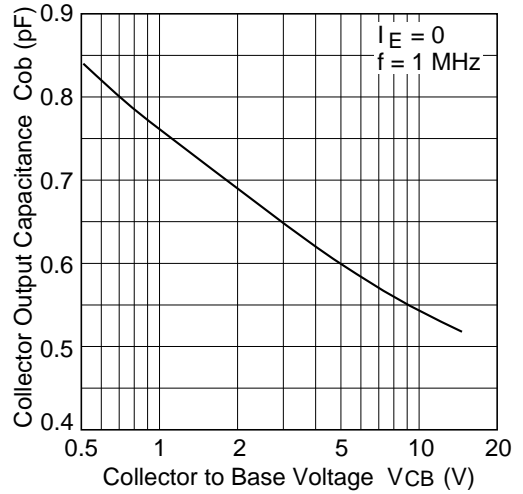

Power Gain vs. Collector Current

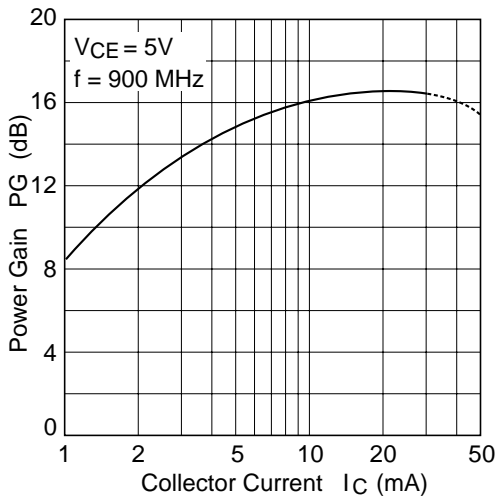

Noise Figure vs. Collector Current

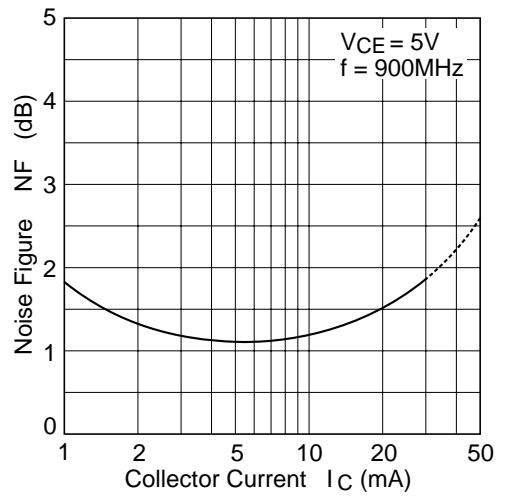

S21 Parameter vs. Collector Current

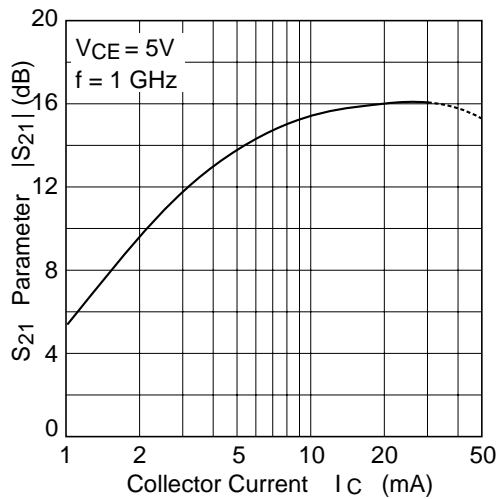

S11 Parameter vs. Frequency

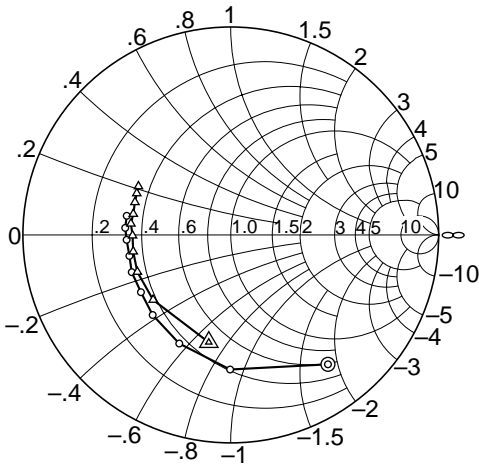

Condition:  $V_{CE} = 5\text{ V}$ ,  $Z_o = 50\ \Omega$   
 200 to 2000 MHz (200 MHz step)  
 ○ — ○ ( $I_C = 5\text{ mA}$ )  
 △ — △ ( $I_C = 20\text{ mA}$ )

S21 Parameter vs. Frequency

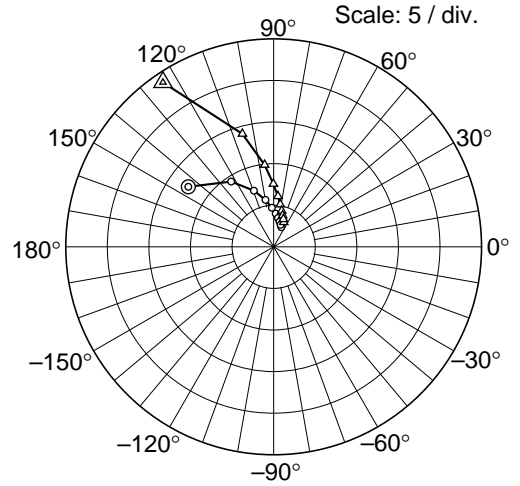

Condition:  $V_{CE} = 5\text{ V}$ ,  $Z_o = 50\ \Omega$   
 200 to 2000 MHz (200 MHz step)  
 ○ — ○ ( $I_C = 5\text{ mA}$ )  
 △ — △ ( $I_C = 20\text{ mA}$ )

S12 Parameter vs. Frequency

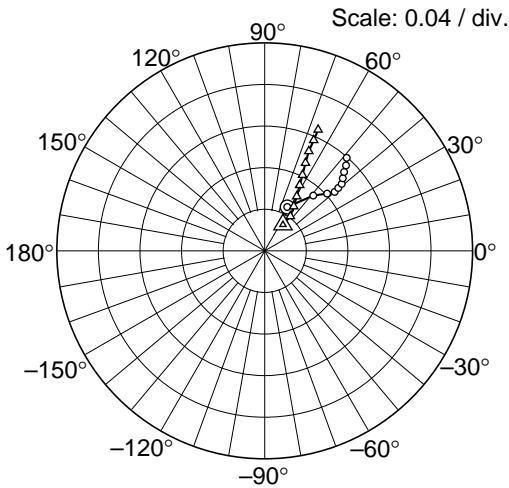

Condition:  $V_{CE} = 5\text{ V}$ ,  $Z_o = 50\ \Omega$   
 200 to 2000 MHz (200 MHz step)  
 ○ — ○ ( $I_C = 5\text{ mA}$ )  
 △ — △ ( $I_C = 20\text{ mA}$ )

S22 Parameter vs. Frequency

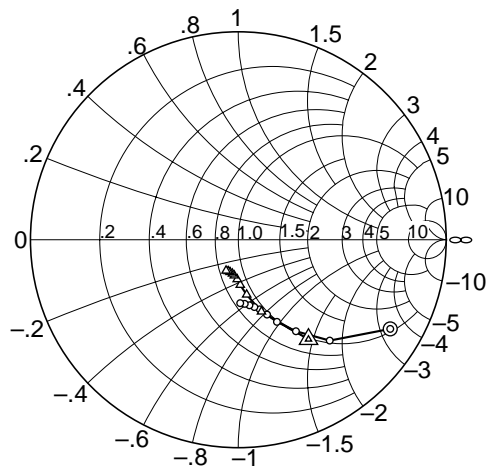

Condition:  $V_{CE} = 5\text{ V}$ ,  $Z_o = 50\ \Omega$   
 200 to 2000 MHz (200 MHz step)  
 ○ — ○ ( $I_C = 5\text{ mA}$ )  
 △ — △ ( $I_C = 20\text{ mA}$ )

## 2SC4926

**S Parameter** ( $V_{CE} = 5 \text{ V}$ ,  $I_C = 5 \text{ mA}$ ,  $Z_O = 50 \Omega$ , Emitter common)

Freq. (MHz)	S11		S21		S12		S22	
	MAG.	ANG.	MAG.	ANG.	MAG.	ANG.	MAG.	ANG.
200	0.777	-53.1	12.52	144.9	0.0475	62.8	0.849	-30.4
400	0.647	-90.3	9.36	123.1	0.0708	48.7	0.655	-47.8
600	0.579	-115.4	7.16	109.4	0.0817	42.5	0.522	-57.8
800	0.538	-134.3	5.73	99.9	0.0880	40.1	0.438	-64.8
1000	0.513	-147.5	4.70	92.6	0.0933	40.5	0.386	-69.0
1200	0.508	-159.4	4.00	86.5	0.0980	41.0	0.350	-72.9
1400	0.500	-168.3	3.49	81.6	0.102	42.9	0.333	-76.6
1600	0.501	-177.3	3.09	76.8	0.108	44.8	0.319	-80.4
1800	0.508	176.2	2.78	72.5	0.113	46.4	0.310	-84.3
2000	0.510	169.6	2.53	68.7	0.119	48.6	0.305	-88.3

**S Parameter** ( $V_{CE} = 5 \text{ V}$ ,  $I_C = 20 \text{ mA}$ ,  $Z_O = 50 \Omega$ , Emitter common)

Freq. (MHz)	S11		S21		S12		S22	
	MAG.	ANG.	MAG.	ANG.	MAG.	ANG.	MAG.	ANG.
200	0.527	-101.6	23.79	124.0	0.0307	55.1	0.587	-54.9
400	0.488	-140.1	14.12	105.5	0.0413	53.4	0.363	-72.2
600	0.482	-158.4	9.89	96.3	0.0510	56.8	0.267	-81.4
800	0.478	-170.3	7.56	90.3	0.0606	59.5	0.218	-87.6
1000	0.474	-179.6	6.10	85.2	0.0716	62.0	0.191	-91.7
1200	0.484	173.6	5.14	81.2	0.0817	63.5	0.174	-96.5
1400	0.481	167.9	4.44	77.4	0.0931	65.1	0.166	-100.0
1600	0.486	161.2	3.92	74.0	0.105	66.1	0.161	-104.4
1800	0.496	156.2	3.52	70.7	0.117	66.1	0.159	-107.9
2000	0.502	152.3	3.20	67.7	0.127	66.2	0.161	-111.9

## Package Dimensions

As of January, 2001

Unit: mm

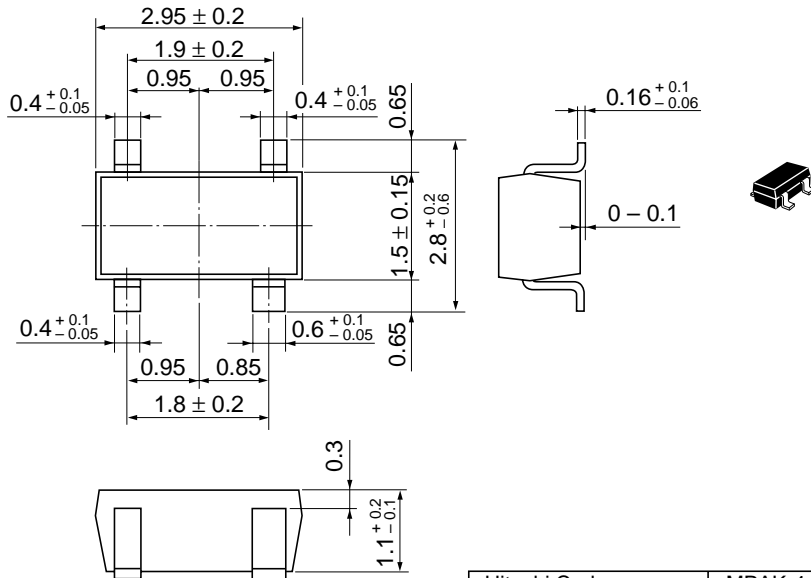

Hitachi Code	MPAK-4
JEDEC	—
EIAJ	Conforms
Mass (reference value)	0.013 g

**Cautions**

1. Hitachi neither warrants nor grants licenses of any rights of Hitachi's or any third party's patent, copyright, trademark, or other intellectual property rights for information contained in this document. Hitachi bears no responsibility for problems that may arise with third party's rights, including intellectual property rights, in connection with use of the information contained in this document.
2. Products and product specifications may be subject to change without notice. Confirm that you have received the latest product standards or specifications before final design, purchase or use.
3. Hitachi makes every attempt to ensure that its products are of high quality and reliability. However, contact Hitachi's sales office before using the product in an application that demands especially high quality and reliability or where its failure or malfunction may directly threaten human life or cause risk of bodily injury, such as aerospace, aeronautics, nuclear power, combustion control, transportation, traffic, safety equipment or medical equipment for life support.
4. Design your application so that the product is used within the ranges guaranteed by Hitachi particularly for maximum rating, operating supply voltage range, heat radiation characteristics, installation conditions and other characteristics. Hitachi bears no responsibility for failure or damage when used beyond the guaranteed ranges. Even within the guaranteed ranges, consider normally foreseeable failure rates or failure modes in semiconductor devices and employ systemic measures such as fail-safes, so that the equipment incorporating Hitachi product does not cause bodily injury, fire or other consequential damage due to operation of the Hitachi product.
5. This product is not designed to be radiation resistant.
6. No one is permitted to reproduce or duplicate, in any form, the whole or part of this document without written approval from Hitachi.
7. Contact Hitachi's sales office for any questions regarding this document or Hitachi semiconductor products.

# HITACHI

**Hitachi, Ltd.**

Semiconductor & Integrated Circuits.  
Nippon Bldg., 2-6-2, Ohte-machi, Chiyoda-ku, Tokyo 100-0004, Japan  
Tel: Tokyo (03) 3270-2111 Fax: (03) 3270-5109

URL	NorthAmerica	: <a href="http://semiconductor.hitachi.com/">http://semiconductor.hitachi.com/</a>
	Europe	: <a href="http://www.hitachi-eu.com/hel/ecg">http://www.hitachi-eu.com/hel/ecg</a>
	Asia	: <a href="http://sicapac.hitachi-asia.com">http://sicapac.hitachi-asia.com</a>
	Japan	: <a href="http://www.hitachi.co.jp/Sicd/indx.htm">http://www.hitachi.co.jp/Sicd/indx.htm</a>

**For further information write to:**

Hitachi Semiconductor  
(America) Inc.  
179 East Tasman Drive,  
San Jose, CA 95134  
Tel: <1> (408) 433-1990  
Fax: <1> (408) 433-0223

Hitachi Europe GmbH  
Electronic Components Group  
Dornacher Straße 3  
D-85622 Feldkirchen, Munich  
Germany  
Tel: <49> (89) 9 9180-0  
Fax: <49> (89) 9 29 30 00

Hitachi Europe Ltd.  
Electronic Components Group.  
Whitebrook Park  
Lower Cookham Road  
Maidenhead  
Berkshire SL6 8YA, United Kingdom  
Tel: <44> (1628) 585000  
Fax: <44> (1628) 585160

Hitachi Asia Ltd.  
Hitachi Tower  
16 Collyer Quay #20-00,  
Singapore 049318  
Tel: <65>-538-6533/538-8577  
Fax: <65>-538-6933/538-3877  
URL: <http://www.hitachi.com.sg>

Hitachi Asia Ltd.  
(Taipei Branch Office)  
4/F, No. 167, Tun Hwa North Road,  
Hung-Kuo Building,  
Taipei (105), Taiwan  
Tel: <886>-(2)-2718-3666  
Fax: <886>-(2)-2718-8180  
Telex: 23222 HAS-TP  
URL: <http://www.hitachi.com.tw>

Hitachi Asia (Hong Kong) Ltd.  
Group III (Electronic Components)  
7/F., North Tower,  
World Finance Centre,  
Harbour City, Canton Road  
Tsim Sha Tsui, Kowloon,  
Hong Kong  
Tel: <852>-(2)-735-9218  
Fax: <852>-(2)-730-0281  
URL: <http://www.hitachi.com.hk>

Copyright © Hitachi, Ltd., 2000. All rights reserved. Printed in Japan.  
Colophon 2.0



This datasheet has been download from:

[www.datasheetcatalog.com](http://www.datasheetcatalog.com)

Datasheets for electronics components.